

# Rhinomanometer NR6

User Manual  
V 9B



## **TABLE OF CONTENTS**

INTRODUCTION	P5
SAFETY/WARNING/CAUTION/STATEMENTS	P6
RISK ASSESSMENT FOR PATIENT CONTACT COMPONENTS	P7
PRODUCT SUPPORT	P9
PACKAGE & CONTENTS	P9
ENVIRONMENTAL REQUIREMENTS	P10
COMPUTER SUPPORTED	P10
PRINTERS SUPPORTED	P10
PRODUCT FEATURES and SPECIFICATION	P10
RHINOMANOMETRY OVERVIEW	P11
PERFORMING A MEASUREMENT	P13
COMMON PROBLEMS, TROUBLESHOOTING	P17
MAINTENANCE MANUAL	P20
CONSUMABLES & ACCESSORIES	P23
CONTACT DETAILS	P23

## **TRADEMARKS**

IBM personal system/2 and PS/2 are trademarks of International Business Machines Corporation.

Microfoam is a trademark of the 3M Company.

WINDOWS is a trademark of Microsoft Company

## **COPYRIGHT NOTICE**

Copyright © G M Instruments Ltd, 2011. All rights reserved.

Copyright Protection.

Software and manuals are copyrighted which means that your right to copy any part of them is limited by copyright law. Making copies or derivative works, except in certain limited instances and except for making copies for archival purposes or as an essential step in the utilisation of the computer program in conjunction with an NR6 Rhinomanometer card, without prior authorisation is prohibited by copyright law and constitutes a punishable violation of such law.

## **CAUTIONS:**

If the NR6 Rhinomanometer is to be used in conjunction with a PC or printer whose power supply is not approved for use in a patient environment, then an isolation transformer which is in compliance with BS EN 60601-1, should be used to power the system. You must use the transformer to ensure that the NR6 is in compliance with BS EN 60601-1.

The use of NR6 near to sources of electromagnetic radiation, such as mobile phones, radio transmitters, x-ray equipment etc, may prevent it from functioning correctly.

Federal (USA) law restricts this device to sale by or on the order of a physician.

The NR6 Rhinomanometer is a medical instrument which is classified as a Type B device.

A Type B device categorisation is used to describe an instrument which:-

Applied parts offer protection to the subject against electrical shock and in the event of a single fault condition arising, leakage current will be limited to less than 0.5mA.

Any incident which results in actual or potential injury or death to a subject while using NR6 should be immediately communicated to GM Instruments at the address below.

NR6 should only be connected to other devices such as computers and printers which comply with EN 60950-1. Unless computers and printers built to EN 60950-1 are used patient safety might be compromised.

Non medical equipment such as computers and printers should be kept out of reach of subjects being tested as such equipment does not comply with medical safety standards.

Servicing can only be carried out by GMI approved and authorised personnel.

No modification of this equipment is allowed.

Patient connection components, may cause an irritation reaction in some patients. Use of such components should be discontinued in patients who exhibit such a reaction.

Certain components are marked single use items. Single use items should not be reused as they could carry infections between subjects.

## STORAGE

The NR6 Rhinomanometer and its accessories should be stored within the following temperature and humidity range:-

Temperature -40°C to +60°C Humidity 20 to 80% RH non condensing

## INTRODUCTION

This manual is organised into a number of sections which deal with the installation, features and use of the NR6 Rhinomanometer.

It includes statutory information, as required for a medical instrument which is CE marked, along with background information on Rhinomanometer. A list of current scientific papers can be downloaded from our web site which is noted below.

It concludes with a section on maintenance and calibration.

If you have any comments on this manual, its associated software manual, or need additional help, please do not hesitate to contact the supplier of this instrument or the manufacturer, GM Instruments on the email addresses noted below.

## TECHNICAL NOTE

This guide assumes you are familiar with your computer's hardware and basic WINDOWS commands. If you are not familiar with these items you may wish to keep a Microsoft manual and your computers users guide close at hand while you are installing your Rhinomanometer.

## CONTACT INFORMATION

GM INSTRUMENTS LTD  
UNIT 6 ASHGROVE WORKSHOPS  
ASHGROVE ROAD  
KILWINNING  
KA13 6PU  
UK

TEI: 01294 554664

FAX: 01294 551154

EMAIL: [gminstruments@aol.com](mailto:gminstruments@aol.com) or  
[enquiries@gm-instruments.com](mailto:enquiries@gm-instruments.com)

[www.gm-instruments.com](http://www.gm-instruments.com)

## SAFETY STATEMENTS

PRODUCT NAME & MODEL No. - RHINOMANOMETER NR6

NAME OF MANUFACTURER G M INSTRUMENTS LTD  
UNIT 6 ASHGROVE WORKSHOPS  
ASHGROVE ROAD  
KILWINNING  
KA13 6PU

MANUFACTURED IN UK

### RHINOMANOMETER LABELS & MEANING



DANGER DO NOT USE IN THE  
PRESENCE OF INFLAMMABLE  
ANAESTHETIC GAS

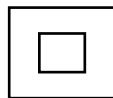

CLASS II EQUIPMENT



TYPE B EQUIPMENT



ATTENTION CONSULT  
DOCUMENTS  
(BEFORE CONNECTING  
READ INSTRUCTIONS)



DANGEROUS VOLTAGE

## WARNING/CAUTION STATEMENTS

Note the comments on page 2 of this manual relating to:-

Computer power supply/patient environment specification/BS EN 60601-1 requirements.

Problems created by electromagnetic radiation and interference.

Federal (USA) restrictions.

Parts marked for single use should not be re-used as no method of sterilisation can be guaranteed, disinfection materials may not be effective and may leave a residue, which could be harmful.

## **RISK ASSESSMENT FOR THE NR6 PATIENT CONTACT COMPONENTS**

The accepted ground-rules for the risks that medical equipment poses to patients are:

### **High Risk**

Items in close contact with a break in the skin or mucous membrane or introduced into a normally sterile body area, eg surgical instruments, syringes & needles, intrauterine devices and associated equipment, dressings, urinary and other catheters - **sterilisation** is required.

### **Medium Risk**

Items in contact with intact mucous membranes, eg respiratory equipment, gastroscopes, or other items contaminated with particularly virulent or readily transmissible organisms, or if the item is to be used on highly susceptible patients - **disinfections** required.

### **Low Risk**

Items in contact with normal and intact skin, eg stethoscopes, washing bowls - **cleaning** and drying usually adequate.

To define the terms within the definitions above:

**Sterilisation** is a process used to reduce an object free from all living organisms.

**Disinfection** is a process used to reduce the number of micro organisms but not usually of bacterial spores: the process does not necessarily kill or remove all micro organisms, but reduces them to a level which is not harmful to health.

**Cleaning** is a process which removes contaminants including dust, soil, large numbers of micro organisms and the organic matter (eg faeces, blood) which protects them. Cleaning is an always useful, sometimes essential, prerequisite to disinfection and sterilisation.

**Decontamination** is a general term for the destruction or removal of microbial contamination to render an item safe. This will include methods of cleaning, disinfection and sterilisation.

In the case of the Rhinomanometer direct patient contact is made by a mask, posterior tubing, anterior tubing, TIP connector and microfoam tape or foam inserts. There is no need to decontaminate these components as they are all single use items. **NB a range of re usable masks is now available.**

There is however concern about the possibility of contamination being deposited onto the flowhead beyond the single use mask and then being available to subsequent users.

There are 2 ways of dealing with this:-

1) A washer - disinfectant could be used to achieve thermal disinfection. This process should be restricted to a maximum temperature of 85°C and all solutions routinely used to reprocess anaesthetic equipment tubing, should be suitable. This processing should be considered between each patient and the calibration of the NR6 checked after such processing. Provided the NR6 can be calibrated the flowhead can be used again.

2) Alternatively an antiviral filter could be placed between the mask and flowhead obviating the need to disinfect the flowhead.

We recommend use of the Intersurgical Filter-guard filter (code 1944). This is specified by Intersurgical to be 99.999% efficient for bacterial/viral filtration and has ports which fit our NR6 mask on one side and our flowhead on the other. This filter is intended for use by one patient only and over a period not exceeding 24 hours. Its use must be restricted to situations approved by Intersurgical. No filter is 100% efficient so you may consider it prudent, if dealing with a patient who has a known or probable infection problem, to decontaminate the flowhead after use even when a filter has been used.



Adult mask (1 use) set for **Posterior** test.



As before but with filter added



Adult mask (1 use) set for **Anterior** test.  
Note blanking plug on black mask port.



As before but with filter added  
Note blanking plug on black mask port.

## PRODUCT SUPPORT

If you have any questions about your Rhinomanometer call your supplier or ourselves. We will be able to advise you and give you help with any problem you may encounter.

When you call for product support, please have the following information available

Your original Rhinomanometer disk(s).

This user guide and a note of your interface (PCI or USB)

The make and model number of your computer & printer.

It may also be helpful if you are in front of your computer when you call. This information will help our personnel to quickly and accurately answer your questions.

## PACKAGE & CONTENTS

NR6 Rhinomanometer.	NR6	ONE
Adult Mask (Re-useable)	NR-RA	ONE
Child Mask (Re-useable)	NR-RC	ONE
Filter (single use)	NR-Filter	ONE
Mask tube caps	NR-Cap	10/pkt
Flowhead and 4 tube set		

### Anterior parts

Anterior Tube Connector	NR/AT/CON	ONE
Anterior Tubing	NR/ANTUB	1 metre lengths
Tip Connectors	NR/TIP/CON	ten/box
Tape for Tip Connectors	NR/TAPE	12/box
Hole Punch for tape	NR/HP	ONE
Foam Inserts Large	NR Large Inserts	24/pkt
Foam Inserts Standard	NR Std Insert	50/pkt
Foam Inserts Small	NR Small Insert	50/pkt

### Posterior parts

Posterior Mouth Tubes	NR/POSTUB	1 metre lengths
-----------------------	-----------	-----------------

2 x CD disks.

Rhinocal calibration checker (Executive versions only)

User Software guide plus System users manual.

## **ENVIRONMENTAL REQUIREMENTS**

### **TEMPERATURE**

The normal operating temperature range is from 15°C to 35°C. The transducers are temperature compensated between those limits but the flowhead calibration will be affected at the rate of 5%/20°C change. The calibration is initially set at 18°C.

### **HUMIDITY**

The operating relative humidity range is from 20% to 80% non condensing.

### **COMPUTERS SUPPORTED**

The software and hardware can be provided in a format suitable for IBM or compatible PC's with a free USB port.. Computers built to BS EN 60950-1 are recommended.

### **PRINTERS SUPPORTED**

As this version of the Rhinomanometer operates in a Windows environment print capability depends on you having installed a printer under Windows. Virtually any printer which works under the version of Windows you have will be suitable.

### **PRODUCT FEATURES**

Your NR6 Rhinomanometer is capable of giving a well defined assessment of the function of the nose and of recording changes within it due to surgical intervention, allergic response or other factors. To achieve this please ensure that you read carefully the sections dealing with using the instrument in pages 11 to 17 of this manual.

### **SPECIFICATION:-**

Size..	27x8x30 cm
Weight..	2 Kgm
Flow Range..	±800cc/sec
Pressure Range.	.±800Pa
Accuracy..	±2%
Supply..	taken from PC.
Standards	Electrical Safety and EMC BS EN 60601-1 series
Warm up time	5 minutes
Operating Temperature	+15 to +35°C
Operating Humidity	20 to 80% RH non condensing
Duty Cycle	Continuous

## **RHINOMANOMETRY OVERVIEW**

The measure of Rhinomanometer or nasal airway resistance depends on measuring nasal air flow and the pressure producing that airflow.  $R = P/F$

Nasal airflow is collected by a mask, which must form an airtight seal round the face and is then passed out through a pneumotachograph head in which the flow is converted to a pressure differential. This differential is transmitted to the NR6 by means of the tubes marked with red and green bands.

Nasal pressure is the more difficult parameter to measure and this is done using one of two standard techniques.

### **POSTERIOR TEST** (detailed on P16)

In the posterior test a tube is placed in the mouth - just long enough to sit on the tongue - and the lips closed round the tube. Provided the soft palate is relaxed the pressure measured by this tube will be the same as the pressure driving airflow through the nose. This pressure signal is taken to the NR6 by means of the tube with the black marker on it. The reference pressure tube (blue) is connected to the mask. Patient co-operation is required to use this technique. A measure of total nasal resistance is obtained from one test.

### **ANTERIOR TEST** (detailed on P14)

In the anterior test the black pressure tube is connected to one side of the nose while airflow is measured through the other side. Resistance is calculated. The pressure tube is then moved to the second side, flow is recorded and resistance is calculated again. The two resistance values are then put into the formula

$$\frac{1}{R_{TOTAL}} = \frac{1}{R_{LEFT}} + \frac{1}{R_{RIGHT}}$$

to calculate total resistance. Pressure connection to the nose is made by means of a tip connector pushed through a small hole punched in microfoam tape, (or a foam insert if the nasal valve performance is not of interest), and linked to the black pressure tube using anterior tubing and an anterior connector. The reference pressure tube (blue) is connected to the mask.

It is essential that the pressure connection is airtight and this should be checked by asking the patient to obstruct the free side of the nose with one thumb and the free end of the tube connected to the tip connector (or foam insert) with their other thumb. If the patient then tries to gently breathe in and out through their nose they will be able to tell you whether or not they feel any air leakage at the tape or foam.

Posterior and Anterior tests can be performed using a fixed reference level (selectable from 75 to 300 Pa or cc/sec) or alternatively under the Broms technique with a radius of 200 units. In either case resistance is calculated when the trace crosses the fix line or arc of the circle.

The recommended reference points are as follows:

Standard posterior	75 Pa
Standard anterior	150 Pa
Broms	200 units

Resistance values averaged over at least 4 breaths is recommended and offered by default.

In addition to resistance values Rohrer coefficients are also calculated for K1 and K2. K0 should be zero as the curve goes through the origin.

K1 represents the laminar flow part of the curve.

K2 represents the turbulent part of the curve.

### **PRINCIPAL POINTS TO NOTE**

- 1) Prepare the patient by having them in a relaxed quiet condition for 15/20 minutes prior to measurements being taken and decongest them.
- 2) Check for leakage of the pressure tube and for good mask fit.
- 3) Ask the patient to breath in a quiet relaxed way - avoid excited rapid manoeuvres.

## PERFORMING A MEASUREMENT

The program has adopted many standard windows conventions and can be controlled by using the mouse, function keys or "hot letter" keys. Most are self explanatory but some features may not be immediately obvious e.g. how to compare one test against another to get % change figures or how to mark a group of files for printout. A software guide has been supplied separately to aid quick referral.

### BATCH TEST FACILITY (Executive version only)

Measurements can be made in full, on a one at a time basis, or alternatively the batch test facility can be used.

Most errors in Rhinomanometer can be attributed to:-

a) Poor patient preparation

They should be in a stable environment for 15 - 20 minutes and blow their nose or be decongested prior to testing. They should also be advised to breathe at a normal rate and level.

or

b) Poor patient connection

The pressure tube and mask must not leak and must be placed correctly on the face to avoid distorting the nose.

Errors arising from a) can be avoided by careful processing of patients prior to testing and those arising from b) by using the batch test facility (Clinical/Research version only). Essentially the batch test facility allows rapid retesting of a patient with automatic comparison of one of the measured parameters and production of mean, standard deviation and coefficient of variation figures for the test runs repeated for that patient.

The process to be followed is therefore, connect and test patient, disconnect patient, reconnect and retest patient. Continue the process until the CV figure drops to an acceptable level.

## TO PERFORM A TEST

The patient should be connected to the instrument only when the screen shows the flow and pressure axis and after checking that the dot lies on the origin of the graph. If the system is not correctly zeroed, press Z for zero or click on the zero button.

### a) ANTERIOR TEST

The anterior test requires no patient co-operation and can therefore be performed on any subject. The technique requires that one side of the nose is used as an extension to the pressure tube (to monitor the pressure component relative to the mask pressure) and this connection is achieved using either:-

- 1) Microfoam tape, a tip connector, anterior tubing, and an anterior connector or
- 2) a foam insert, anterior tubing, and an anterior connector.

If resistance of the total nose, including the nasal valve area is required, the tape method should be used, but if the nasal valve area is not of interest, the foam inserts may be used. The black mask connector should be sealed for anterior use, as it is not required.

Flow is measured on the open nostril. The mouth should be closed during the test and once the resistance figure for one side has been obtained the role of the nostrils is reversed by moving the tape assembly or foam insert to the other nostril.

It is a fundamental requirement of this technique that an airtight connection of the instrument pressure tube onto one side of the nose be made with as little distortion as possible. Satisfying this criteria, results in the best possible accuracy.

**If foam inserts are to be used, substitute the foam insert for the TIP connector and TAPE shown below.**

### ANTERIOR TEST PREPARATION

- a) make a hole in the tape using the smallest die on the punch supplied.

- b) fit a tip connector and 15cms of anterior tubing to the tape as shown. (or 15 cm of anterior tubing onto a foam insert).

De-grease the nose with an appropriate agent such as surgical spirit.

- c) fix the tape onto the nose (or foam into the nose), position the tube against the cheek where it will be during the test, and check for leakage by blocking the tube with your finger, ask the subject to block their open nose with their thumb and gently breathe in and out

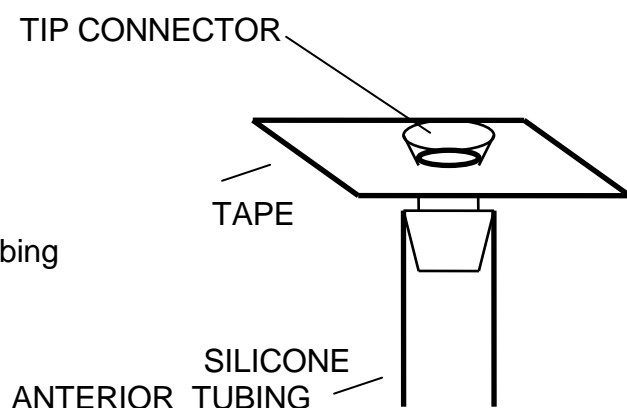

FOAM INSERT  
(alternative to tape/Tip)



through their nose. Any leakage will be felt by them.

- d) if airtight, secure the tube in this position by bringing the mask up to the face, taking care to position it on the bridge of the nose. Ask the patient to hold the mask assembly there.
- e) connect the anterior tubing free end to the pressure tube (marked black) using the anterior tube connector.
- f) ask the patient to maintain pressure on the mask to achieve an airtight seal while closing his lips and breathing through his nose. Ensure that the patients fingers do not obstruct the output from the flowhead.

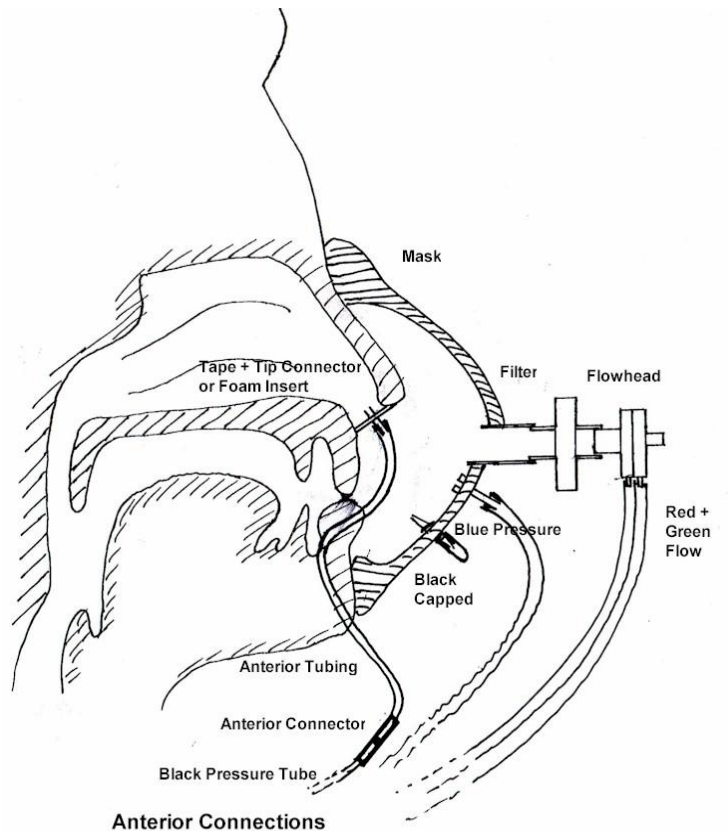

There are two principal hazards associated with this technique.

- a) The patient will press so hard that the anterior tube collapses and obstructs completely - this will result in the display showing an almost vertical line and can be corrected by asking the patient to apply a little less pressure.
- b) If the respiratory rate is too high there will be a tendency to create an open loop on the display. In the event of this occurring, the patient should be given time to become familiar with the mask and then asked to breathe more slowly.



Hole Punch      Anterior Tape      Anterior TIP Con      Anterior Tubing      Anterior Tube Connector



Foam Inserts



Anti Viral Filter



Single use Mask

## b) POSTERIOR METHOD

The posterior method allows direct measurement of total nasal resistance from a single manoeuvre without any direct contact with the nose, and as such is perhaps the preferred technique.

The mask assembly comprises a pneumotachograph to measure flow and a mouth tube onto which can be added disposable mouthpieces to measure pressure. The subject is asked to put the disposable tube in his mouth and close his lips round it while breathing through the nose. Under ideal conditions the pressure developed in the mouth will equal that behind the nasal passages and by dividing this pressure by the flow passing, a measure of resistance is obtained.

$$\text{Resistance} = \frac{\text{Pressure}}{\text{Flow}}$$

This technique does not interfere in any way with the nasal passages but it does have the disadvantage that it depends on the mouth area having an uninterrupted connection to the respiratory tract. It is therefore essential that:

- a) the subject does not bite the mouth tube:
- b) the end of the tube is not blocked by tongue, cheek or saliva:
- c) the soft palate is relaxed and the back of the tongue is held down in the mouth.

Difficulty may be experienced in training some subjects to perform satisfactorily - success figures of around 80% for adults and 50-70% for children may be typical.

Two techniques have been found useful in training subjects.

1. Allow the subject to obtain visual feedback by watching the screen. The clinician, by looking at the trace, can tell the patient when a valid test has been obtained and within a short time the patient will associate a successful test with a certain posture and measurement can be made.

2. Ask the subject to breathe through his nose deeply with his mouth shut and adopt a position that allows his cheeks to puff out with each expiration. Try it first of all without the mask and then with the mask in position. If the cheeks can move in and out, the soft

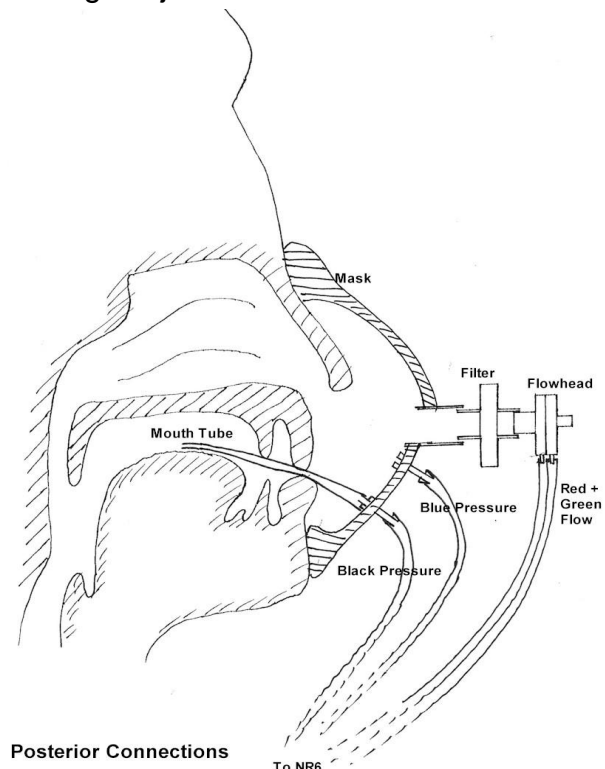

palate, tongue etc. must be correctly positioned and posterior measurements can be made.

3. Keeping the head erect and the jaw forward during measurements, can also help keep the back of the mouth in direct contact with the nasal driving pressure signal.

## **COMMON PROBLEMS & TROUBLESHOOTING**

The NR6 is almost perfect - it's the patients which cause the problems! The principal problems are as follows:-

1) There is leakage in the pressure tube circuit. The trace is almost vertical and its only when using the Broms technique that you can calculate results because the trace will not reach the 75 Pa or 150 Pa sample point threshold line used in the standard technique.

Check the pressure tube connections to the patient and to the NR6 box. (black ringed tube)

2) There is leakage in the flow circuit. The trace is almost horizontal indicating a very high resistance or little or no flow component.

Check the mask fit and the tube runs between the flowhead and the NR6 box. (red & green) Check that the black mask port is capped when doing an anterior test.

3) The curves produced are very open indicating a large hysteresis i.e. the flow and pressure components are out of phase.

This is often caused by the patient breathing too rapidly but might be physiological especially in a highly constricted nose.

4) The spot does not move when a pressure or flow is applied, or moves in a very erratic way. This suggests that the A/D card has not been installed properly (has it been set to Board 0 and 4 channel differential?) or there is no connection between the NR6 and the PC (Is the green light on the front of NR6 illuminated?)

## HOW TO STERILISE REUSABLE PARTS

Never reuse or re-sterilise any patient applied part whose original package was labelled with **FOR ONE TIME USE, SINGLE USE, DISPOSE AFTER USE** or equivalent wording. When in doubt about whether a patient applied part can be re-sterilised, always consider it for one time use. The following sterilisation procedure is intended for removable, reusable patient applied parts manufactured by GMI. For a product that is sold by GMI but not manufactured by GMI, refer to the sterilisation procedures in that product's operating manual where appropriate.

**DO NOT STERILISE THE INSTRUMENT.** To sterilise patient applied parts follow these directions:

- 1) Place each part in a suitable vented sterilisation pouch (e.g. Tyvak side or port). Include a sterility indicator designed for use with Ethylene Oxide and heat seal the package with a device specifically designed for this purpose.
- 2) Place the sealed packages in a sterilisation chamber designed for 100% ethylene oxide gas. After loading the packages according to the sterilisation chamber manufacturer's directions, close and secure the chamber door.
- 3) Evacuate the sterilisation chamber to a pressure of 0.01 atmospheres (7.6 mm Hg).
- 4) Fill the sterilisation chamber with 100% ethylene oxide gas until the chamber pressure reaches 0.2 atmospheres (152 mm Hg).
- 5) Increase the sterilisation chamber temperature to 48 C.
- 6) Maintain the sterilisation chamber temperature at 48 C for 210 minutes (3.5 hours).
- 7) Reduce the sterilisation chamber temperature to room temperature. Purge ethylene oxide from the sterilisation chamber according to manufacturer's directions and local environmental regulations.
- 8) After sterilisation place the sealed packages in a quarantined, ventilated area away from human contact for at least 2 days to allow any residual ethylene oxide gas to disperse. Follow local environmental regulations selecting the area and posting necessary cautionary statements.
- 9) Examine each sealed package's sterility indicator. Discard or re-sterilise any part if its sterility indicator is negative or the package is broken or opened. Store the sterilised packages in a cool, dry place.

Sterilisation chamber conditions may be affected by age, lack of periodic re-calibration, metering errors or other problems. The effectiveness of the sterilisation procedure with your specific equipment should be validated by an independent, accredited testing laboratory to certify sterility and package integrity after sterilisation. Check with a local accredited laboratory for further guidance. Never make the assumption that re-sterilised patient applied parts are sterile until sterility certification has been established. GMI assumes no responsibility that this sterilisation procedure for patient applied parts

will be effective with your specific sterilisation equipment. Independent sterility certification by an accredited testing laboratory is the only validation method that can establish this level of confidence.

## Maintenance Manual NR6

A calibration check should be made, and if required the instrument adjusted, in the following circumstances:-

If the pressure or flow transducers are changed.

If the flowhead is contaminated with dust or other particles or has been washed or disinfected.

If some time has elapsed since the last calibration. (Ideally a check should be made before each testing session.)

If there is any uncertainty about the results achieved.

Two transducers are employed. One for the flow measurement and one for the pressure. They may be set using static individual calibration units such as liquid column for pressure and a float gauge for flow.

### Calibration Equipment

A. Pressure Gauge - a liquid column covering the range 0-500 Pa (51mm H<sub>2</sub>O) It is an added convenience if this is connected in the manner shown because used in this way adjustment to the desired pressure level is more easily achieved.

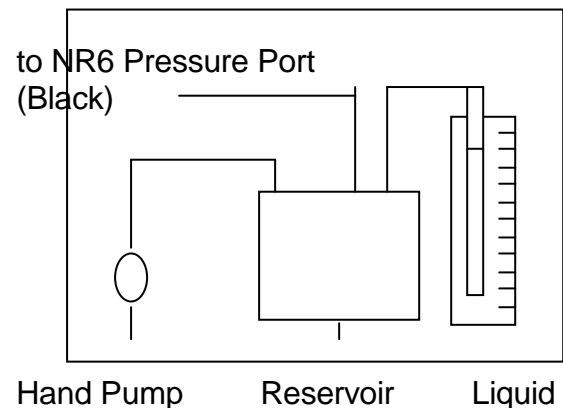

### Column

B. Flow Gauge - such as a rotameter covering the range 0-500cm<sup>3</sup>/sec. (0-30 l/min) and an adjustable source of flow with a variable voltage supply. Such a motor is available from manufacturers of vacuum cleaners and the speed at which it runs and therefore the flow it produces can be controlled by powering it from a variable transformer.

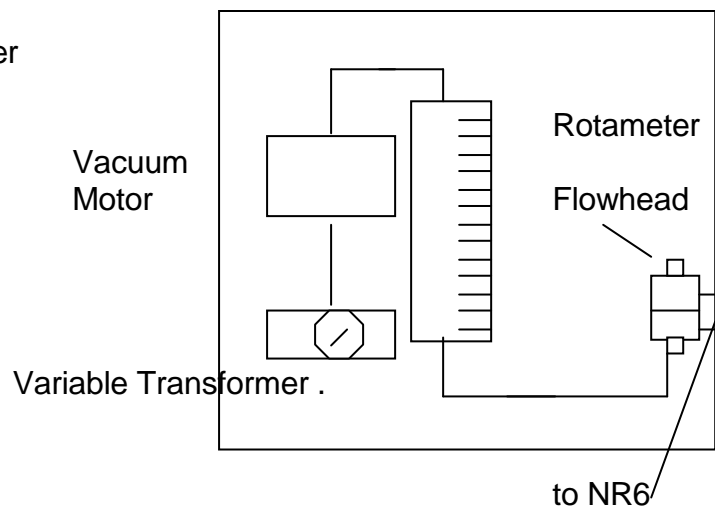

The procedure to be employed is as follows:-

- a) Switch on the instrument and allow 5 minutes warm-up time.
- b) Select calibration from the setup menu bar item. Zero the output.
- c) Apply a flow of 300cm<sup>3</sup>/sec. (18 litres/min.) to the flowhead and if the value shown on the screen is not correct, adjust the flow calibration potentiometer, marked VR2 inside the NR6 until the reading is correct.
- d) Remove the flow and check that the value returns to zero. If it does not, reset the zero position, apply the flow and, if necessary, re-adjust the flow calibration potentiometer. (VR2)
- e) Apply a pressure of 300 Pa (31mm H<sub>2</sub>O) to the black input nozzle and, if the value on the screen does not read 300, adjust the potentiometer VR5 inside the NR6 until it does read correctly.
- f) Remove the pressure and check that the value returns to zero. If it does not, reset the zero position, re-apply the pressure and, if necessary, make a further adjustment of the pressure calibration potentiometer.

## Maintenance

The routine maintenance which is required is as follows:

- a) Check regularly the condition of the **pneumotachograph** which is mounted on the mask and the condition of the plastic tubes which connect the mask to the instrument. The pneumotachograph should be kept clean, as dust build-up on the gauze will result in incorrect results. The gauze, mask, tip connectors and tubes can be washed, subjected to sterilising solution and can be gas sterilised, but must be thoroughly dried out prior to making measurements. They cannot be autoclaved. The tubing should not be used if it kinks or if it becomes slack on the pneumotachograph or instrument connector tubes. It should be replaced by a new length.
- b) Conditions of various instrument to PC interconnecting cables should be checked regularly to look for damage to insulation.
- c) Should the **enclosure require cleaning** for any reason, unplug it from the PC and wipe it with a damp cloth, or a cloth soaked in a mild alcohol based solution or cleaning wipes. Do not allow liquid to run into the enclosure.

## Servicing

The NR6 contains two transducers with associated instrumentation amplifiers, balance and gain controls along with an isolated +5 volt to  $\pm 12V$  DC converter. Full circuit diagrams are available on request and service adjustments are noted below.

### Transducer set up adjustments

1. Switch on the NR6 and allow 5 minutes warm up.
2. Measure the voltage between test point 5 and test point 4 using a sensitive DC voltmeter. Adjust pressure offset pot VR4 to give a reading of 0 volts.
3. Measure the voltage between test point 5 and test point 6 using a sensitive DC voltmeter. Adjust flow offset pot VR1 to give a reading of 0 volts.

### Transducer calibration adjustments

1. Pressure Channel. The gain of the pressure transducer is adjusted by means of VR5.
2. Flow Channel. The gain of the flow transducers is adjusted by means of VR2.

## Consumable & Accessories List

<u>Description</u>	<u>Code</u>	<u>Standard Unit</u>
<b>Supplied with each NR6</b>		
Flowhead	NR-FL	ONE
Adult Masks (Re-use)	NR-RA	ONE
Child Masks (Re-use)	NR-RC	ONE
Filter	NR-Filter	ONE
Mask tube caps	NR-Cap	10/pkt
<b>Anterior parts</b>		
Anterior Tube Connector	NR/AT/CON	ONE
Anterior Tubing	NR/ANTUB	1 metre lengths
Tip Connectors	NR/TIP/CON	ten/box
Tape for Tip Connectors	NR/TAPE	12/box
Hole Punch for tape	NR/HP	ONE
Foam Inserts Large	NR Large Inserts	24/pkt
Foam Inserts Standard	NR Std Insert	50/pkt
Foam Inserts Small	NR Small Insert	50/pkt
<b>Posterior parts</b>		
Posterior Mouth Tubes	NR/POSTUB	1 metre lengths
<b>Available to order</b>		
All of the parts listed above +		
Adult Masks (single use)	NR/SA	ONE
Child Masks (single use)	NR/SC	ONE
Rhinocal (supplied with the Clinical/Research NR6 but also available separately)	NR/CAL	ONE

**MANUFACTURED BY:** GM INSTRUMENTS LTD  
UNIT 6 ASHGROVE WORKSHOPS  
ASHGROVE ROAD  
KILWINNING  
KA13 6PU  
UK

TEI: 01294 554664  
FAX: 01294 551154  
EMAIL: [gminstruments@aol.com](mailto:gminstruments@aol.com)  
[enquiries@gm-instruments.com](mailto:enquiries@gm-instruments.com)  
[www.gm-instruments.com](http://www.gm-instruments.com)